

MARK II WITH EXTENDABLE BOOM - 300KG

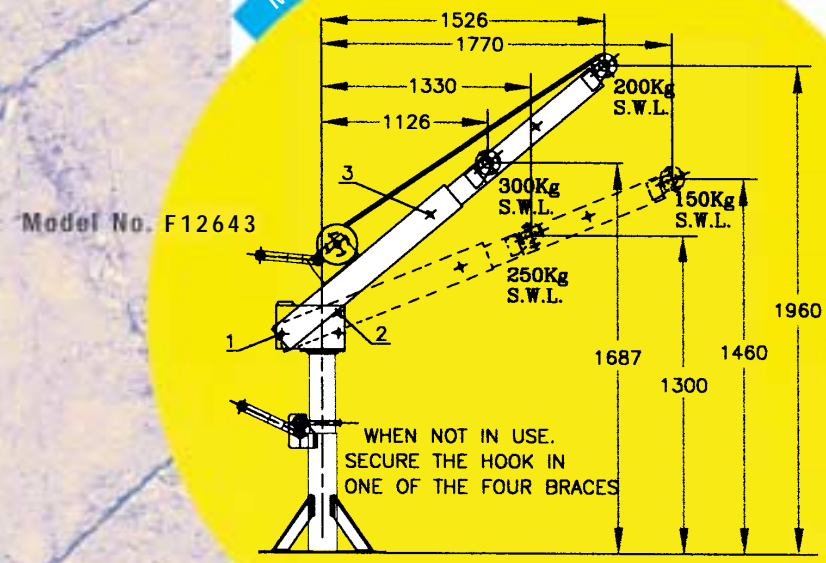

MARK II WITH EXTENDABLE BOOM - 500KG

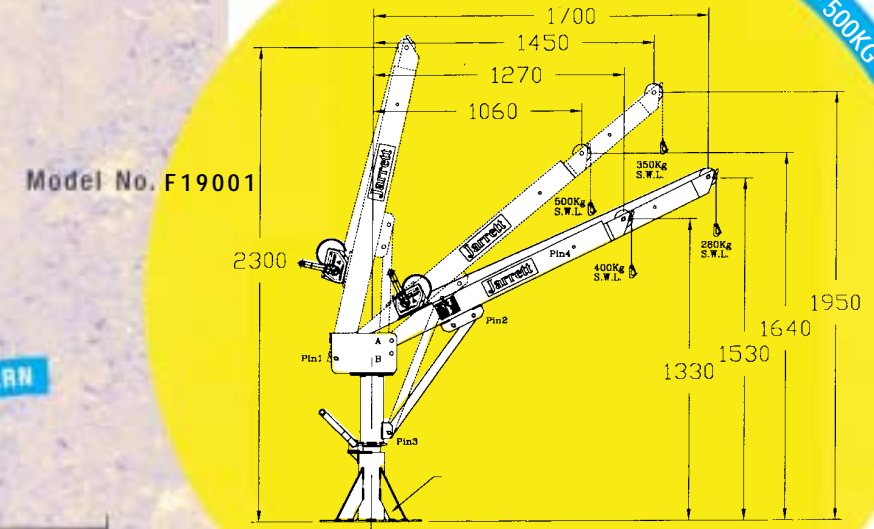

BOLT DOWN PATTERN

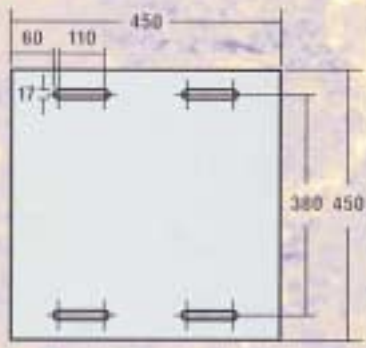

KG Specified Weight Limit
All measurements in mm

Backsaver Cranes are available in Powder Coated or Galvanized Finish

AVAILABLE FROM:

Jarrett Industries

Manufactured in Australia by
Jarrett Synergy Pty Ltd
ACN 072 842 445

Corner of Humphries Terrace
and Regency Road, Kilkenny
South Australia, 5009

Telephone: +61 8 8243 9100
Facsimile: +61 8 8243 9185

www.jarrett.com.au

Sales Enquiries:
athan.lekkas@jarrett.com.au

Export Brochure

SPECIFICATIONS HEREIN MAY CHANGE WITHOUT NOTICE. BACKSAVER CRANE IS NOT FOR THE MOVEMENT OF HUMANS.

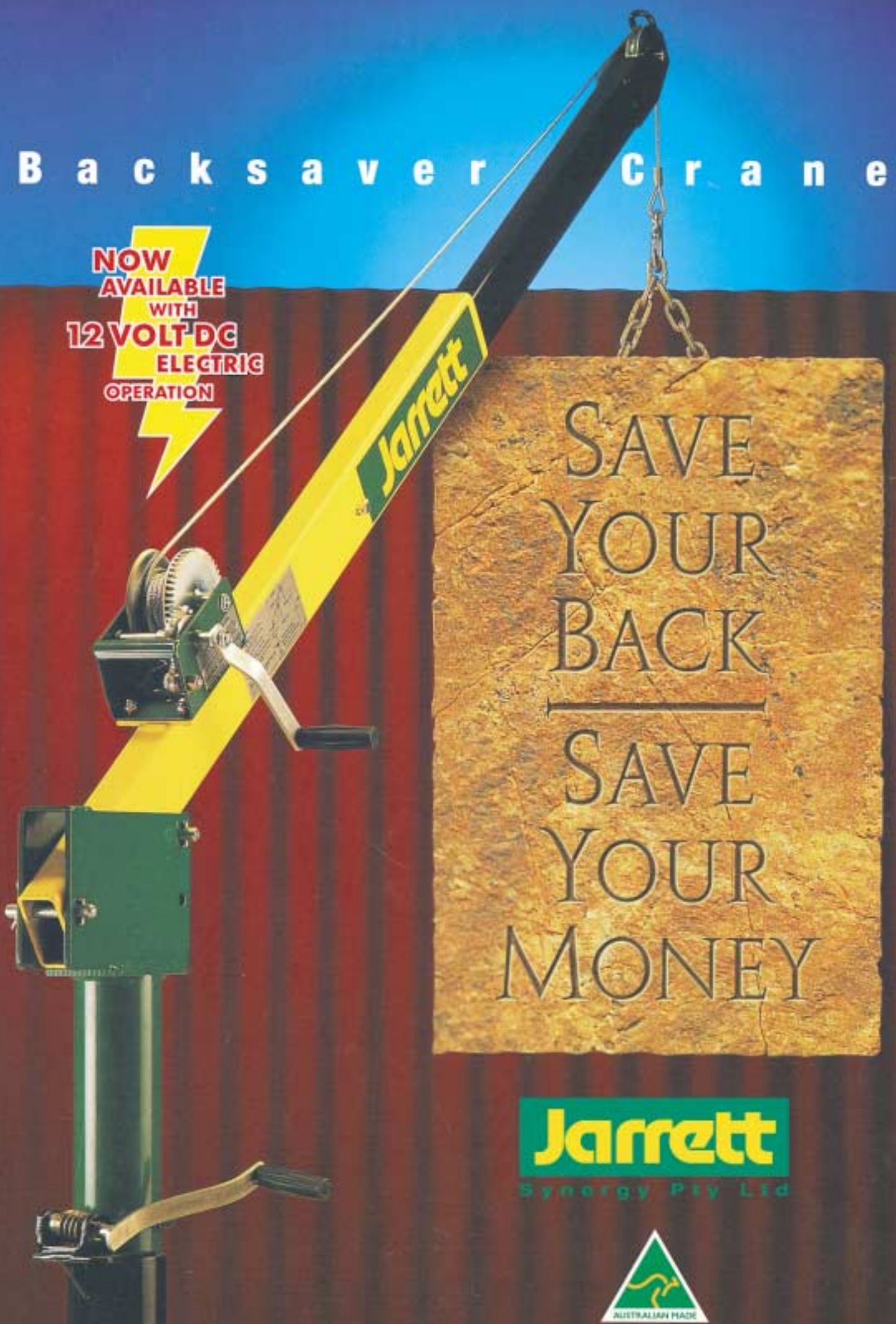

Jarrett
Synergy Pty Ltd



There Is An Easier Way Don't take the risk to your back, equipment or business. If it's got to be lifted, do it the easy way, with a Jarrett Backsaver Crane. Designed and developed by Jarrett Industries, Australia's largest manual winch manufacturer, the Backsaver Crane has the capacity to safely, simple and effectively lift and place loads of up to 300kg and 500kg.

300kg and 500kg Capacity Lift The lifting capabilities of the Backsaver Crane are supplied by a 300kg and 500kg manual brake winch. To raise the load simply wind the handle, to lower the load wind the handle in the reverse direction. The winch incorporates a load friction brake which is automatically activated when the handle is released - keeping the load safely in position at all times. **360°**

Mechanical Slewing The Jarrett Backsaver Crane is fitted with 360° mechanical slewing by means of a worm drive gear. This eliminates the danger of the crane boom swinging out of control when the load is taken up. The boom can only be rotated (slewed) by operating the slewing control handle. This important safety feature keeps the load under control at all times - essential for one person operation. **Choice of Boom Length** With a choice of two models, the Backsaver Crane suits a host of reach and lift requirements. The Mark I model has a boom reach of over 1 metre at its' 300kg and 500kg lift position and the Mark II model has an extendible position. Both models have a choice of boom angle settings for even greater adaptability.

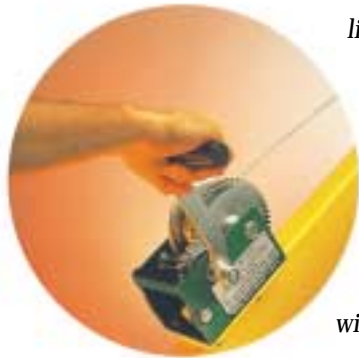

Versatile & Simple The simple design of the Backsaver Crane means it is easy to assemble and can be fitted almost anywhere - to jetties, utes or tray tops and to a wide variety of fixed platforms. When a Backsaver Crane is vehicle mounted and the time comes to change vehicles it is simple to remove and leaves only four holes. The Backsaver Crane is then ready to install elsewhere. The Backsaver Crane's simple operation means that little can go wrong and service support is available through Jarrett Spare Parts distributors around Australia. The Backsaver Crane provides the perfect lifting solution for tradesmen, farmers, delivery drivers and anyone who has to lift loads of anything from fuel drums, jet skis, small boats, motor bikes, car engines, ride-on-mowers, cement mixers, farm machinery, livestock, fencing, brick cutters and even tractor tyres - the possibilities are endless. In fact if you have ever thought, "There's got to be an easier way", chances are Jarrett has already found it.

Jarrett
Industries

