

COPYRIGHT ALL RIGHTS RESERVED

DO NOT SCALE

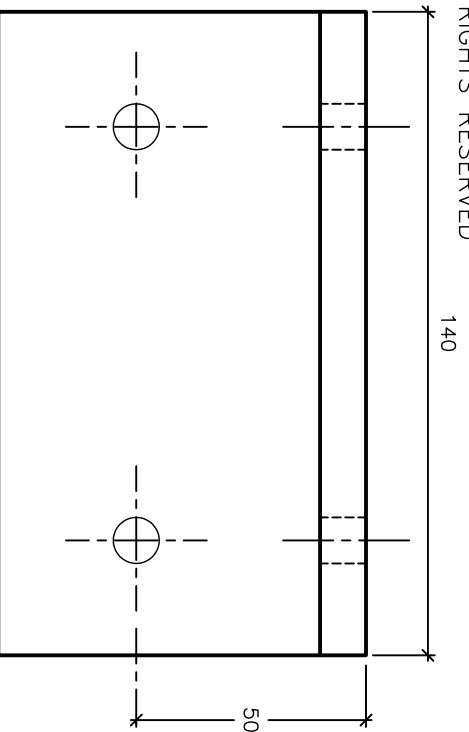

PLAN VIEW

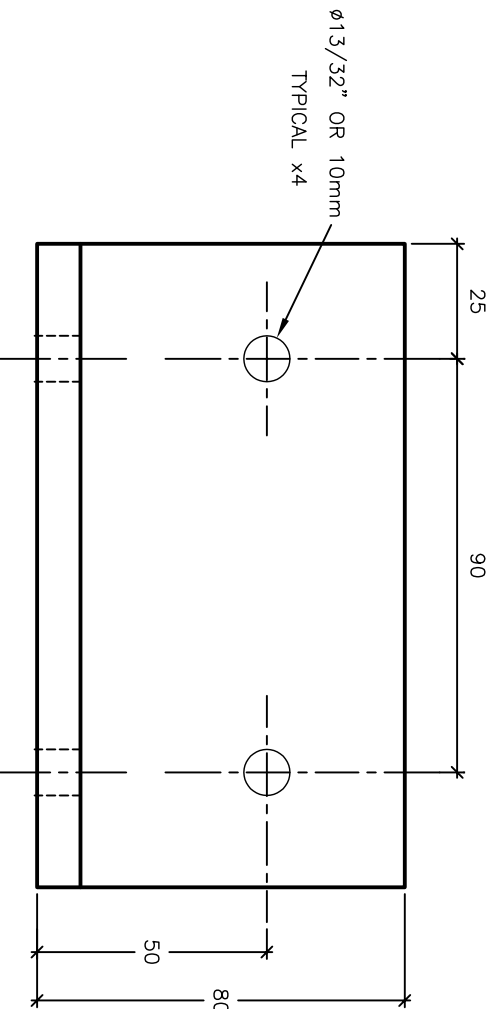

FRONT VIEW

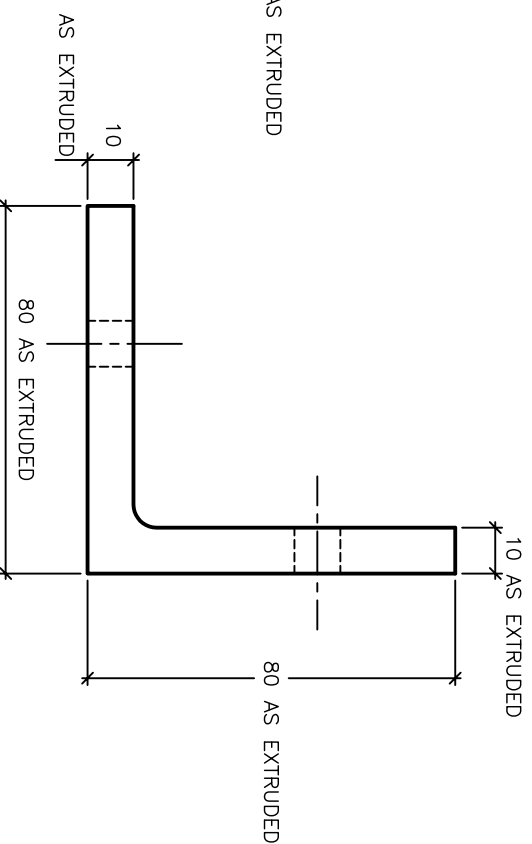

SIDE VIEW

NOTE-THE MATERIAL USED IS TO BE OF
 GRADE 6063 T5 OR 6061 T5
 ALUMINIUM EXTRUSION.
 -THE EXTRUSION IS 80x80x10
 STRUCTURAL ANGLE.
 *COMALCO SECTION No. E:20709
 -ALL SHARP EDGES ARE TO BE
 REMOVED.
 -APPROX. WEIGHT OF BRACKET 0.545kg
 -MATERIAL MASS 4.071 kg/m

DRAWING HAS BEEN REDRAWN FROM A3-290 (3/4/86)

**MARINE DOCK SYSTEMS
 PTY LTD**

**PONTOON
 FRAME BRACKET**

BKT-FRAME-290

TOLERANCES
 LINEAR ±1.0
 ANGULAR ±0.2°
 HOLE CTRS ±0.5

SCALE N.T.S.
 DRAWN BJM
 DATE 7.11.95

DRAWING No. **A4-290**
 REV B